

# 4.7 L N2 PILOT BOTTLE

## AEX/BDN-5

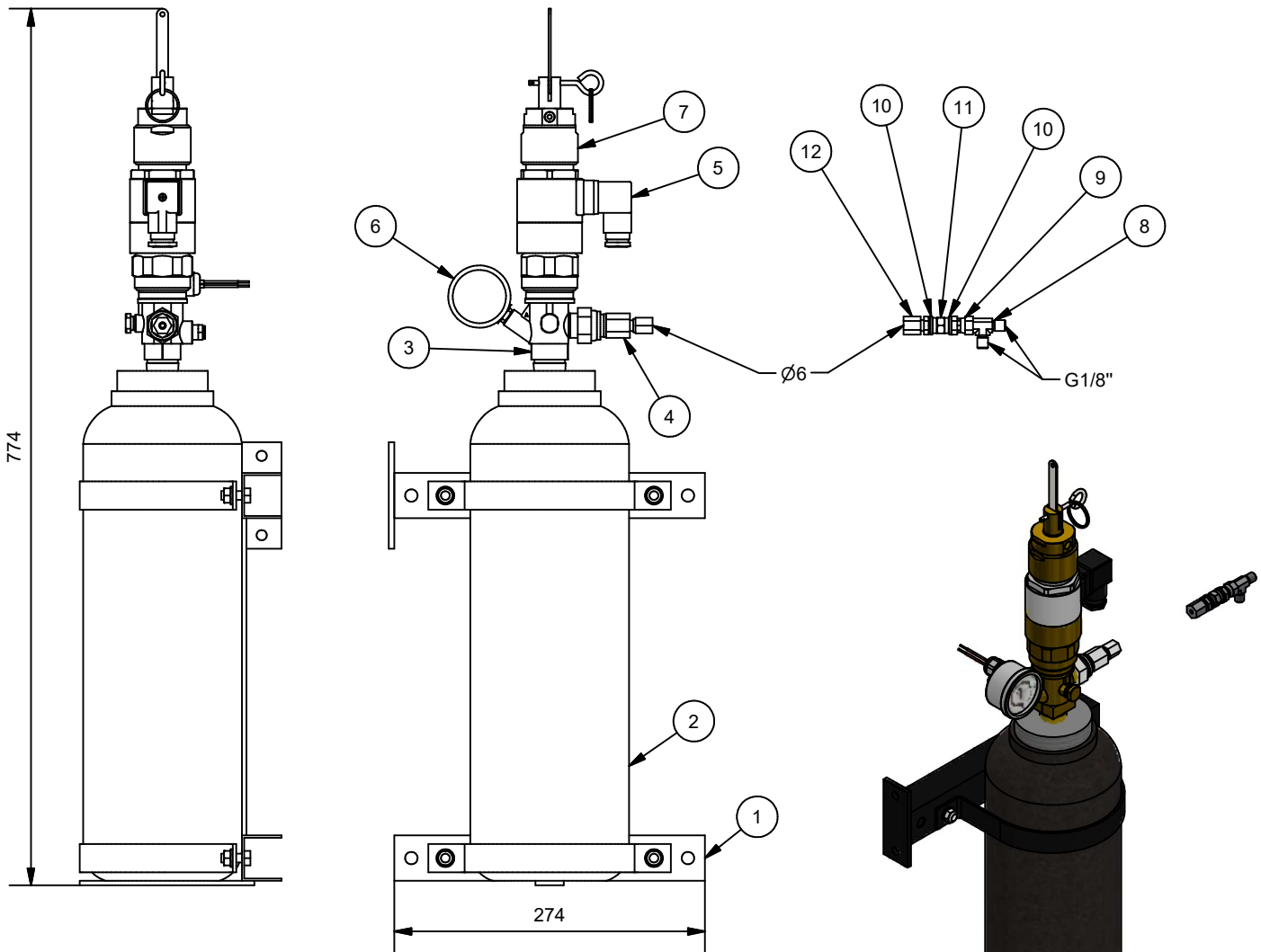

Specifications	
Cylinder capacity	4.7 L
Cylinder material	34CrMo4
Colour	Black RAL 9004
Cylinder test pressure	250 bar
Content	N2
Pressure	111 bar

Parts list		Parts list	
Nº	Reference and Description	Nº	Reference and Description
1	HP274 - Fitting for Pilot Bottle	7	AEX-FKAM2 - Manual / Pneumatic Actuator
2	BN2425E - Pilot bottle 4.7 L for N2	8	V-T18 - 1/8" tee
3	AEX-IGV - Exhaust Valve	9	V-RRMFHG18 - Male 1/8" female 1/8" fitting
4	V-A21PC6 - Adapter tube 6	10	AN-JM18 - Gasket 1/8" metalbuna
5	AEX-IGAE - Electric Actuator	11	V-A18 - Adapter female 1/8" female 1/8"
6	AEX-IGMCNC100 - Pressure gauge with contact	12	V-A18C6 - Adapter 1/8" to pipe 6

Sheet code:	Solution sheet:	Reference:	Drawn:	Date:	Revised:	Date:	Revision:	Format:
AEX-FTC-61-010	FK-5-1-12	AEX/BDN-5	DCM	28-09-23	ENC	28-09-23	1.1	A4